

Bostrom[®]

S E A T I N G

LO PROFILE
BAJA[™]

OPERATION AND SERVICE PARTS MANUAL

This seat conforms to
FMVSS 207 and 302 in effect
at time of manufacture

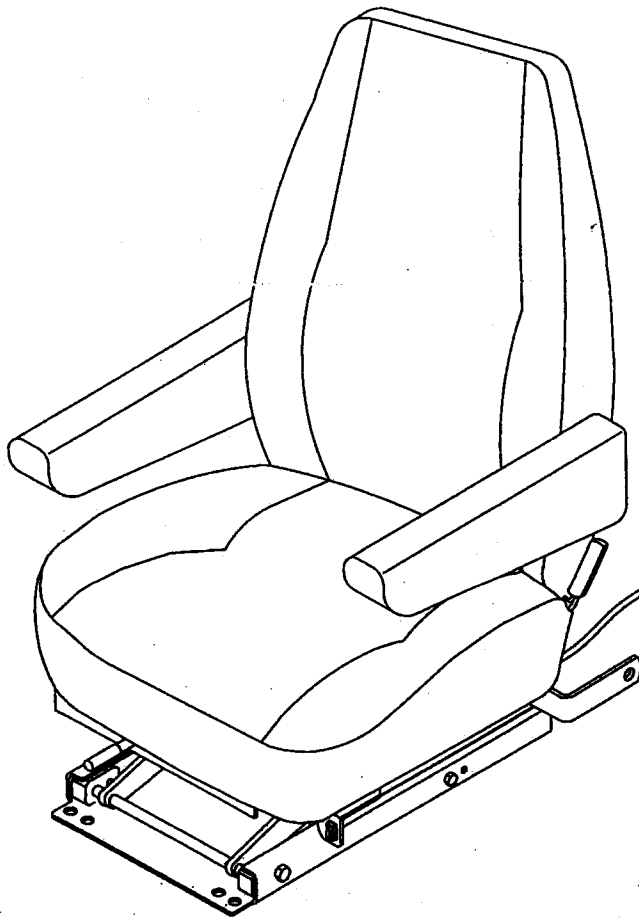

Seat shown with Mid Back

CATALOG NO.
1107646-032

© 1992 BOSTROM SEATING INC.
REV B - 7/00

OPERATION WARNING

WARNING

SERIOUS INJURY MAY OCCUR IF HEAD CLEARANCE IS NOT ADEQUATE. BEFORE DRIVING OR RIDING IN VEHICLE, ENSURE THAT THERE IS ADEQUATE HEAD CLEARANCE AT MAXIMUM UPWARD TRAVEL OF SEAT. SEE OPERATION MANUAL.

To check for adequate head clearance, sit in the seat and slowly raise it to its maximum upward position (see Comfort Adjustments).

SEAT BELTS SHOULD BE WORN AT ALL TIMES WHEN OPERATING THE VEHICLE.

Federal Motor Vehicle Safety Standard

This seat conforms to Federal Motor Vehicle Safety Standards (FMVSS) 207 and 302 in effect on the date of manufacture.

It is the responsibility of the installer to ensure that proper seat fastening hardware and seat belt anchorages (seat belt and tether belt system) are used in accordance with FMVSS 209 and 210.

To achieve compliance with FMVSS 207, use only high strength fasteners and heavy duty washers when installing seat assembly.

Bostrom
SEATING

Vigo Road
P.O. Box 566
Piedmont, AL 36272
(256) 447-9051
www.bostromseating.com

COMFORT ADJUSTMENTS

After installation the following comfort adjustments can be made to ensure the best performance.

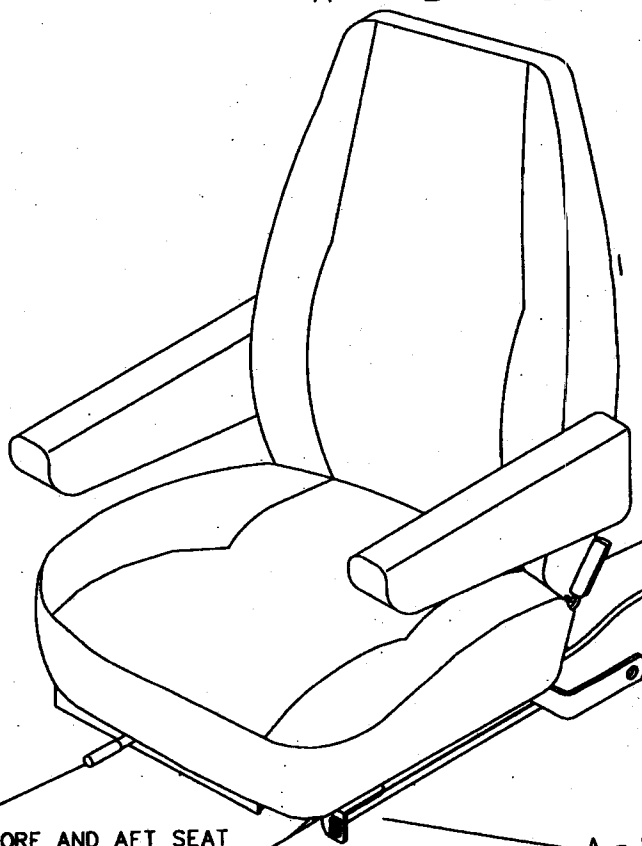
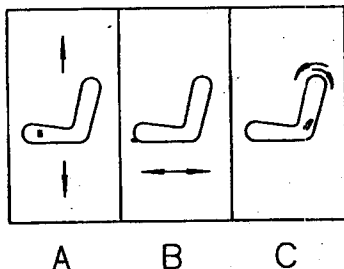

B - FORE AND AFT SEAT POSITION ADJUSTMENT
FORE AND AFT ISOLATION
 Hold lever to left to adjust seat position forward or backward. Isolation is provided when lever is in center (straight forward) position. To lock out move lever to right.

A - WEIGHT AND HEIGHT ADJUSTMENT

To raise seat push the top portion of the air valve. To lower seat push the lower portion of the air valve. When adjusted properly the seat should not top nor bottom against the end limits of the vertical travel under normal driving conditions. Adjusted height position should aid drivers visibility and vehicle control.

C - BACK ANGLE ADJUSTMENT
 Lean forward slightly to remove pressure from seat back, hold handle rearward to adjust to any position within range.

ILLUSTRATED PARTS BREAKDOWN

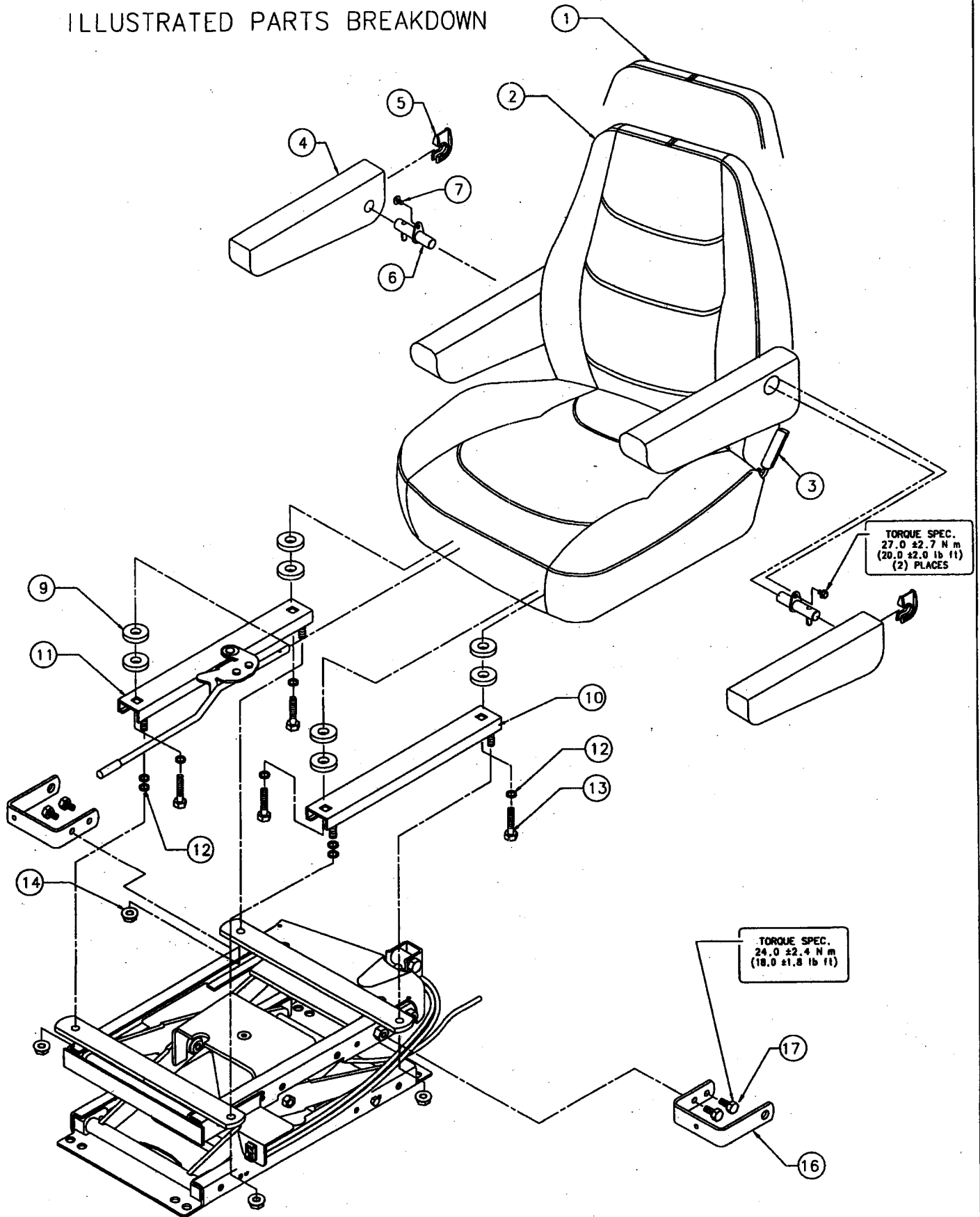

ALWAYS ORDER REPLACEMENT PARTS BY PART NUMBERS—
NOT REFERENCE NUMBERS

ILLUSTRATED PARTS BREAKDOWN

TORQUE SPEC. TYP.
 $33.0 \pm 3.3 \text{ N m}$
 $(25.0 \pm 2.5 \text{ LB FT})$

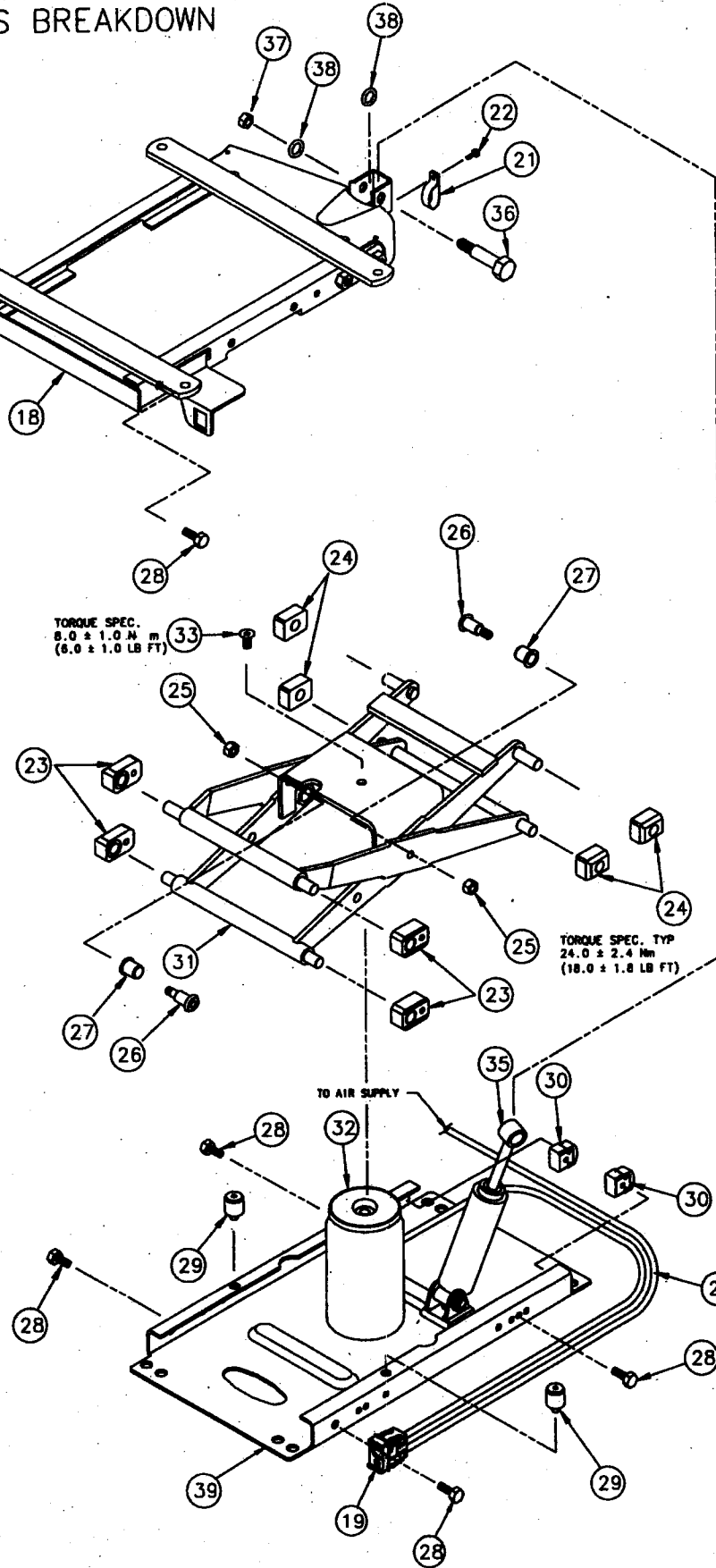

ALWAYS ORDER REPLACEMENT PARTS BY PART NUMBER-
 NOT REFERENCE NUMBERS

PARTS REPLACEMENT LIST

ORDERING INSTRUCTIONS : Order by Part Number , NOT Reference Number .

HOW TO USE : Find the corresponding part that you wish to replace on the exploded view illustration and note its reference number . Refer to list below and record part number , quantity required and description .

Order cover and pad kits and armrest by color and material .

ORDER FROM : Your truck dealer or Bostrom distributor for your area .

Ref. No.	Part No.	Description	Qty.	Ref. No.	Part No.	Description	Qty.
1.	**	High Back Upper		18.	6200675-001	Upper Plate Assy.	1
2.	**	Mid Back Upper		19.	6222209-001	Height Control Valve Includes item 19-22	1
	6200845-001	High Back Frame Assy. Not Shown		20.	*	Air Line	5.9LF
	6200931-001	Mid Back Frame Assy. Not Shown		21.	*	Air Line Clamp	1
	6200009-001	Seat Foam , Not Shown		22.	*	Screw #10 .24*	1
	6200762-001	Back Foam , High Back Not Shown		6222076-001	Suspension Hardware Kit , Includes items 23-30		
	6200827-001	Back Foam , Mid Back Not Shown		23.	*	Bearing Block	4
3.	6201619-001	Recliner Handle	1	24.	*	Slide Block	4
4.	**	Armrest Assy.		25.	*	Nut M8	2
5.	6222159-001	Armrest Insert	1	26.	*	Pivot Bolt	2
6.	6222106-001	Armrest Shaft Kit , Includes items , 5 , 6 and 7		27.	*	Bearing	4
7.	*	Screw 5/16x1/2 Hex Tap	1	28.	*	Screw Cap M8	6
8.	6222028-001	Slide Rail Kit , Includes items 9 - 14		29.	*	Rubber Bumper	2
9.	*	Washer Flat ZP	8	30.	*	Stop Block Assy.	2
10.	*	Seat Adjuster Non-Lock	1	31.	6222112-001	Lever Assy.	1
11.	*	Seat Adjuster w/Handle	1	6222084-001	Air Spring Assy . Includes items 32-34		
12.	*	Washer Flat	6	32.	*	Air Spring	1
13.	*	Screw Cap M8x30MM	4	33.	*	Screw M8x1.25x25MM	1
14.	*	Nut Lock	4	34.	*	Screw-FLT HD M8* Not Shown	1
15.	6222005-001	ICP Bracket Kit , Includes items 16 and 17		6222079-001	Damper Kit , Includes items 35-38		
16.	*	ICP Bracket	2	35.	*	Damper	1
17.	*	Screw Cap M8x12MM	4	36.	*	Shoulder Bolt M8	2
				37.	*	Nut Lock , M8	2
				38.	*	Washer Flat	2
				39.	6201073-001	Lower Base	1

* Except as noted , kits contain all items denoted by asterisk listed below each kit part number .

** See your dealer or Bostrom authorized distributor for Upper , Armrest , Suspension Cover or Cover pad kit part numbers appropriate for your seat .

REMOVAL / REASSEMBLE

Suspension Rebuild Bearing / Slide Block Replacement

1. Bleed all air from line . Disconnect air supply line to seat . Using air valve , exhaust all air from air spring . Remove complete seat assembly from vehicle .
2. Remove seat / back assembly (1) and slide rails (10) and (11) . Using slide rail handle , move seat assembly rearward , remove the two back bolts (13), move the seat forward until front bolts (13) can be removed. Remove slide rails by removing nuts (14) .
3. Block suspension up with a spacer placed between the base riser (39) and the upper plate (18) .
4. Remove air spring assy. by removing screw cap (33) and screw cap located on bottom of plate (39) , disconnect air line (20) from air spring assy. (32) .
5. Remove damper assy. (35) , remove bottom bolt then top bolt (36) .
6. Remove screw caps (28) from upper plate bearing blocks (23).
7. Remove stop blocks (30) by removing screw caps (28) .
8. Remove upper plate Assy. (18) by lifting and sliding it forward until bearing blocks (23) can be removed from cutouts in channel of Upper Plate Assy. (18) , move upper plate Assy. (18) rearward until slide blocks (24) can be removed . **Be careful not to pinch fingers in lever assembly .**
9. Remove screw caps (28) from lower front bearing blocks (23) and slide lever assy. (31) forward until bearing blocks (23) are removed from lower base (39) slide lever assy. rearward until slide blocks (24) are removed from lower base . **Be careful not to pinch fingers in lever assy.**
10. Remove shoulder bolts (26) and nuts (25) from pivots of lever assembly (31) and inspect . Replace if worn .
11. Replace bearings (27) at pivots on lever assy. (31) by pushing the old out and pressing in new . Flange of bearings (27) should be on the side of inner lever assy.
12. Reassemble in reverse order . **Torque pivot shoulder bolts (26) to 18+/- , 1.8 ft-lbs.**
13. Put new bearing blocks (23) and slide blocks (24) on levers with beveled surfaces outward and slide levers with blocks into channels of lower base (39) **Torque Screw caps (28) to 25+/- 2.5 ft-lbs.**
14. After putting bearing blocks (23) and slide blocks (24) on levers , assemble upper plate assy. (18) over bearing blocks and slide blocks . Line up screw caps (28) with bearing blocks (23) and **Torque screw caps to 25+/- 2.5 ft.lbs .**
15. Manually move suspension up and down to make sure there are no clearance problems . **Be careful not to pinch fingers in linkage .**
16. Block up suspension and reinstall air spring assy. (32) . Place air spring so that fitting is facing rear of seat . **Torque air spring screw top (33) to 6.0+/- 1.0 ft-lbs . Install bottom screw and Torque 3.0+/- 1.0 ft-lbs.**
17. Reconnect air line (20) to air spring by pushing air line into fitting .
18. Reinstall stop blocks (30) and line up screw caps with stop blocks , **Torque screw caps to 25+/- 2.5 ft-lbs.**
19. Reinstall damper assy. (35) .
20. Reinstall slide rails (10) , (11) and washers (9) to seat / back assy. Install seat / back assy. to suspension assy. by using washers (12) and nuts (14) .

REMOVAL / REASSEMBLE

Seat / Back Assembly Removal / Reassemble

1. Move seat to rearward position , remove screw caps (13) and washers (12) and (9) . Move seat to forward position and repeat same procedure .

Air Spring Assemble / Removal

1. Using air valve raise seat to its maximum height , remove seat from vehicle .
2. Block suspension up with a spacer placed between the lower base (39) and the upper plate (18). Release air pressure from air spring so that seat is supported by spacer .
3. Disconnect the air line (20) from air spring assy. (32) Remove top screw (33) and bottom screw , remove air spring assy. from suspension .
4. Install new air spring so that air line fitting is facing rear of suspension , Install top screw (33) and Torque to 6.0+/- 1.0 ft-lbs . , Install bottom screw and Torque to 3.0 +/- 1.0 ft-lbs.
5. Reinstall air line by pushing line into fitting of air spring assy.
6. Fill air spring assy. with air and remove spacer block .

Damper Replacement

1. Be sure seat is at maximum height . Add air if needed .
2. Move seat to full forward position to gain working room.
3. Remove shoulder bolts (36) and washers (38) and hex nuts (37) , remove damper assy.
4. Install new damper assy. with flanges of bearings to the outside of suspension . Add washers (38) as shown , install shoulder bolts (36) and hex nuts (37).